

TT20/TT21 SERIES TECHNICAL SPECIFICATIONS

TT20

Combustion chamber W/D: 340/271
Weight in kg: 116

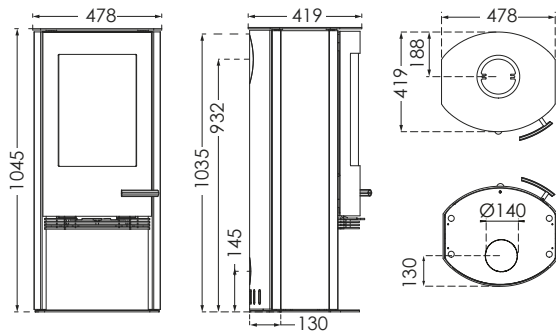

TT20R/TT21R/TT21RL/TT21RH

Combustion chamber W/D: 340/271
Weight in kg: 117/126/121/128

* Applies to models: TT21R/TT21RL/TT21RH

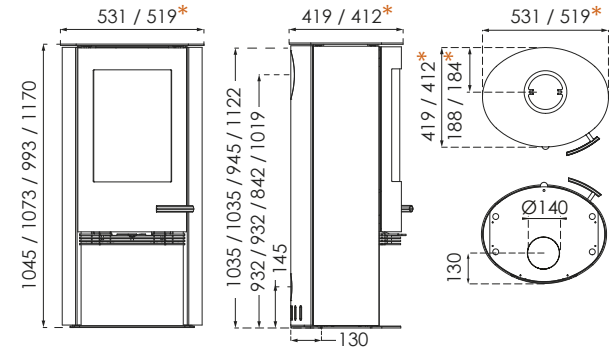

TT21RS**/TT21RHS

Combustion chamber W/D: 340/271
Weight in kg: 174/181

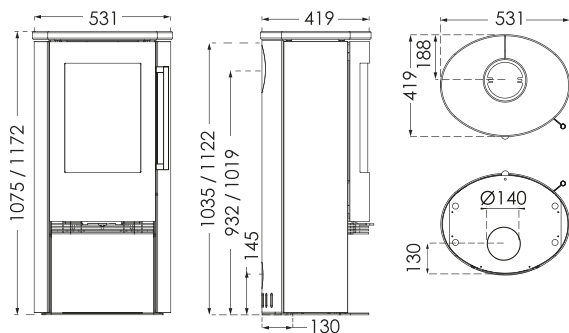

TT21RS-HST***

Combustion chamber W/D: 265
Weight in kg: 285/290

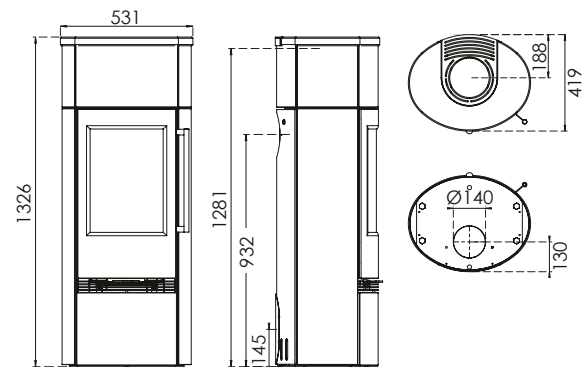

****TT21RS:** TT21RS-WH/TT21RS Grey/TT21RS Black/TT21RS "Matte light" soapstone/
TT21RS "Classic" marbled soapstone

*****TT21RS-HST:** TT21RS-HST "Matte light" soapstone/TT21RS-HST "Classic" marbled soapstone

TT20/TT21 SERIES TECHNICAL SPECIFICATIONS

TT20BAZIC

Combustion chamber W/D: 340/271 Weight in kg: 99

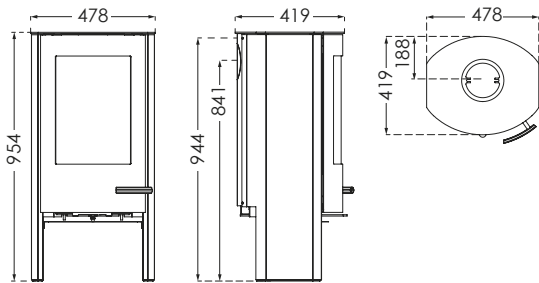

TT20BAZIC R

Combustion chamber W/D: 340/271 Weight in kg: 99

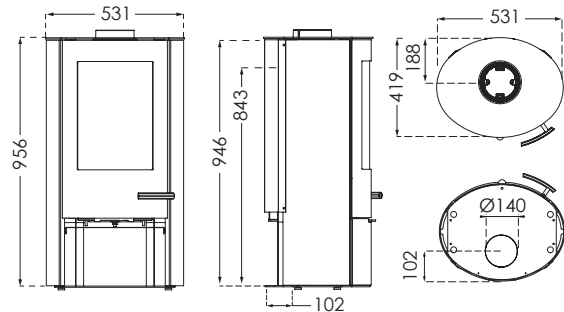

TT21RHS-HST

Combustion chamber W/D: 340/271 Weight in kg: 272

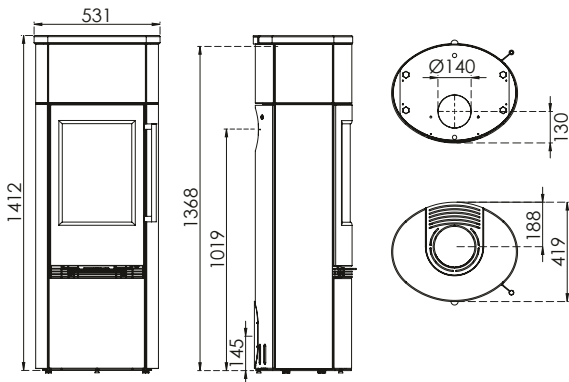

TT21RHT

Combustion chamber W/D: 340/271
Weight in kg: 145 + 48 kg Powerstone

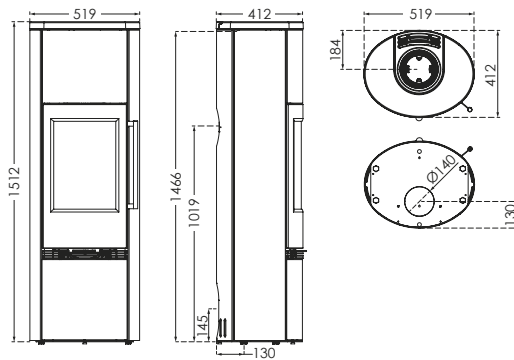

DISTANCE TO COMBUSTIBLE MATERIAL

TT20/TT21 SERIES

WITH UNINSULATED FLUE PIPE

TT20 + TT20BAZIC + TT20R + TT20BAZIC R + TT21R + TT21RS + TT21RL + TT21RH + TT21RHS + TT21RHT

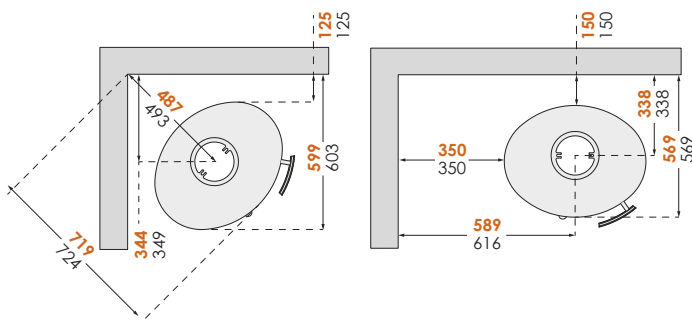

WITH INSULATED FLUE PIPE

TT20 + TT20BAZIC + TT20R + TT20BAZIC R + TT21R + TT21RS + TT21RL + TT21RH + TT21RHS + TT21RHT

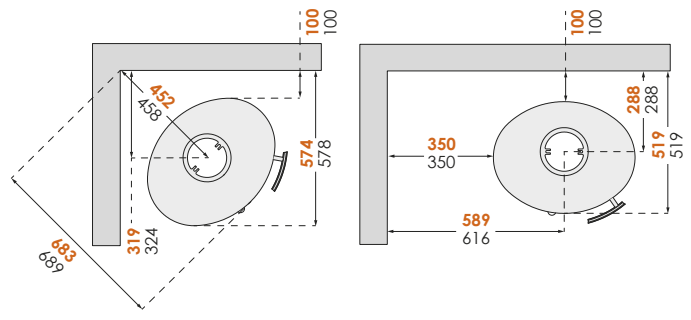

In order to avoid discolouration of painted and treated surfaces, TermaTech recommends the same distance from flammable materials as for non-flammable materials. This distance increases the convection itself around the stove and also eases cleaning. All distances relate solely to the distance of the stove from flammable materials. No account has been taken of national requirements for the use of stove flues or their distance from flammable materials.

NB! All height dimensions are without adjusting feet. Measurements are in mm.